

更改 REV	設 變 內 容 MODIFICATION
A	ECN02716
B	ECN03307

- NOTES :
- MATERIAL :
INSULATOR : HIGH TEMPERATURE THERMOPLASTIC , UL94V-0.
COLOR : BLACK
CONTACT : PHOSPHOR BRONZE.
 - APPLICATION : SD&HS SD&SDHC&MMC&MMCplus&xD
 - PART NO : 7ESMD-X0-0008

PLATING :

- F CONTACT AREA : Gold Flash PLATED OVER Ni
- SOLDER AREA : Tin PLATED OVER Ni
- B CONTACT AREA : 10 μ " Au PLATED OVER Ni
- SOLDER AREA : Tin PLATED OVER Ni

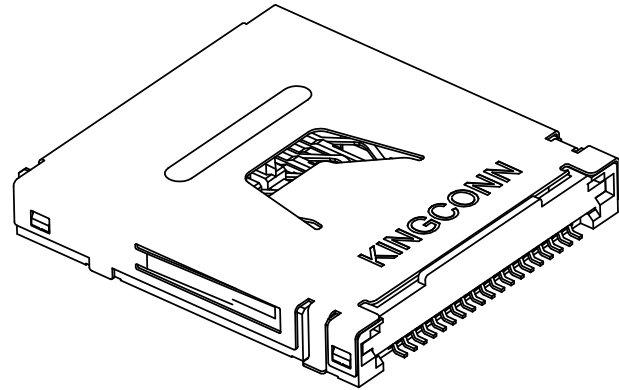

GENERAL TOLERANCE		KINGCONN 皇海科技股份有限公司	
X \pm 0.50	X $^{\circ}$ \pm 5 $^{\circ}$	名 稱(TITLE) Multi-Card CONNECTOR	
.X \pm 0.30	.X $^{\circ}$ \pm 2 $^{\circ}$		
.XX \pm 0.20	.XX $^{\circ}$ \pm 1 $^{\circ}$		
單 位(UNIT) mm	料 號(PART NO.) 7ESMD-X0-0008	圖 號(DWG NO.) 7ESMD-X0-0008-B	
審 核(APPROVAL)	核 對(CHECKED)	製 圖(DRAWN)	比 例 SCALE 1:1
			張 數 SHEET 1 / 3
			角 法 REV B



更改 REV	設 變 內 容 MODIFICATION
A	ECN02716
B	ECN03307

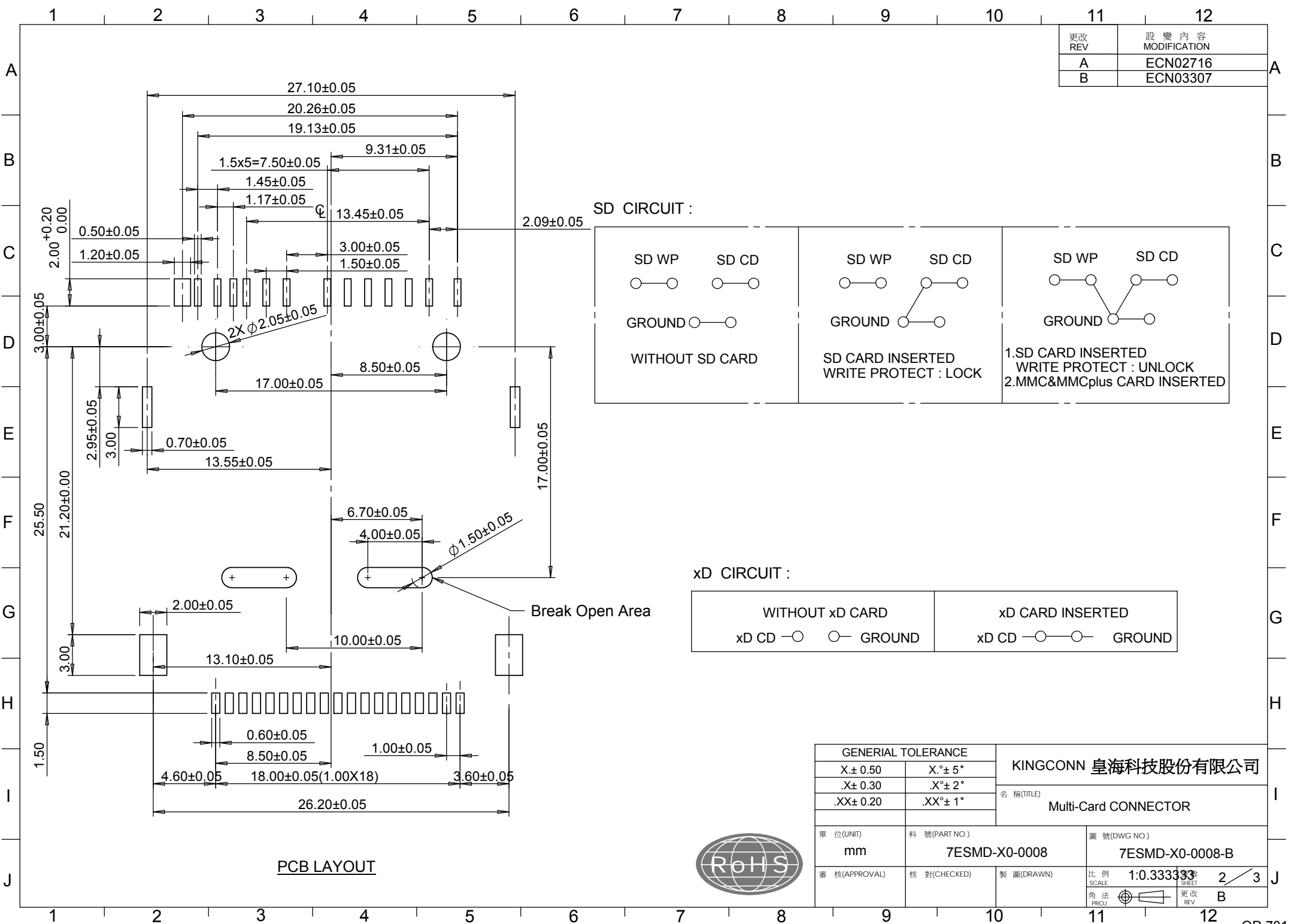

SD CIRCUIT :

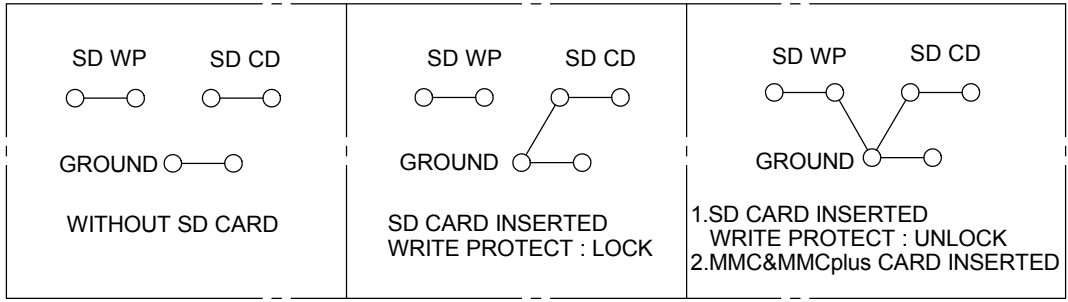

xD CIRCUIT :



PCB LAYOUT



GENERAL TOLERANCE		KINGCONN 皇海科技股份有限公司	
X±0.50	X.°±5°	名 稱(TITLE) Multi-Card CONNECTOR	
.X±0.30	.X°±2°		
.XX±0.20	.XX°±1°		
單 位(UNIT) mm	料 號(PART NO.) 7ESMD-X0-0008	圖 號(DWG NO.) 7ESMD-X0-0008-B	
審 核(APPROVAL)	核 對(CHECKED)	製 圖(DRAWN)	比 例 SCALE 1:0.333333 2/3 角 法 PROJ
			更 改 REV B

更改 REV	設 變 內 容 MODIFICATION
A	ECN02716
B	ECN03307

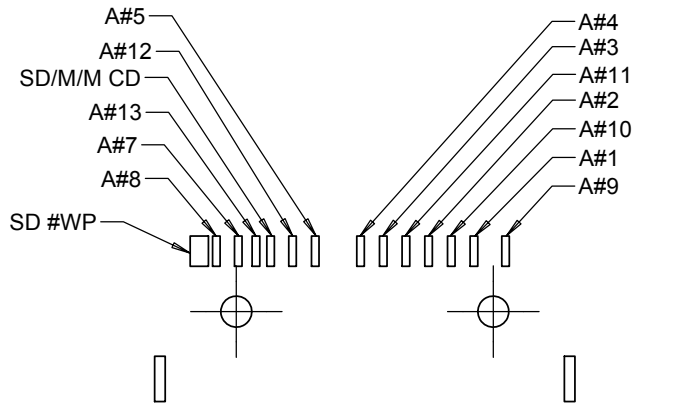

PIN ASSIGNMENT:

PIN NO.	MEMORY CARD PIN NO.	PIN NO.	MEMORY CARD PIN NO.
A#1	SD/MM-1 (DAT3)	xD#18	(VCC)
A#2	SD/MM-2 (CMD)	xD#17	(D7)
A#3	SD/MM-3 (GND)	xD#16	(D6)
A#4	SD/MM-4 (VCC)	xD#15	(D5)
A#5	SD/MM-5 (CLK)	xD#14	(D4)
A#7	SD/MM-7 (DAT0)	xD#13	(D3)
A#8	SD/MMCplus-8 (DAT1)	xD#12	(D2)
A#9	SD/MMCplus-9 (DAT2)	xD#11	(D1)
A#10	MMCplus-10 (DAT4)	xD#10	(D0)
A#11	MMCplus-11 (DAT5)	xD#9	(GND)
A#12	MMCplus-12 (DAT6)	xD#8	(-WP)
A#13	MMCplus-13 (DAT7)	xD#7	(-WE)
		xD#6	(ALE)
		xD#5	(CLE)
		xD#4	(-CE)
		xD#3	(-RE)
		xD#2	(R/-B)
		xD#1	(GND)

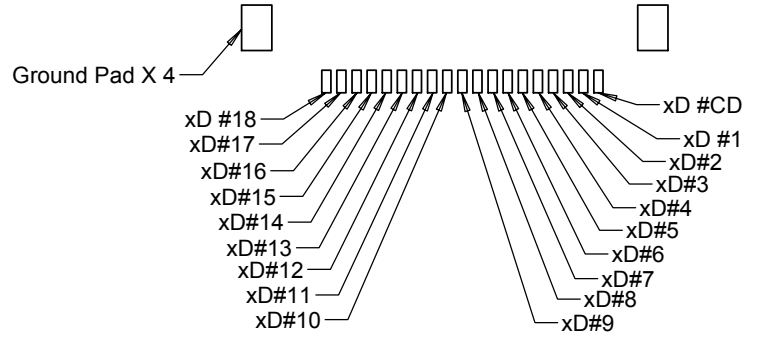
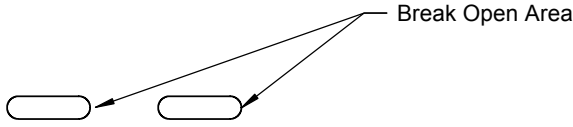

PCB LAYOUT

(SD/M/M : SD&HS SD&SDHC&MMC&MMCplus CARD)

GENERAL TOLERANCE		KINGCONN 皇海科技股份有限公司	
X±0.50	X.°±5°	名 稱(TITLE) Multi-Card CONNECTOR	
.X±0.30	.X°±2°		
.XX±0.20	.XX°±1°		
單 位(UNIT) mm	料 號(PART NO.) 7ESMD-X0-0008	圖 號(DWG NO.) 7ESMD-X0-0008-B	
審 核(APPROVAL)	核 對(CHECKED)	製 圖(DRAWN)	比 例 SCALE 2:1
			張 數 SHEET 3 / 3
			角 法 PROJ 更改 REV B

