

更改 REV	修改 MODIFICATION
A	ECXXXXA

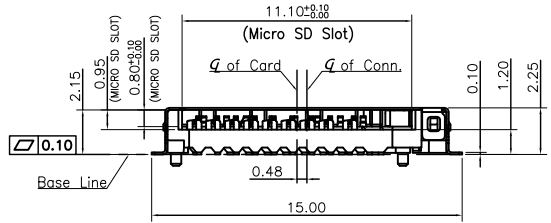

GENERAL TOLERANCE		KINGCONN 皇海科技股份有限公司	
X ± 0.50	X ° ± 5°	名 稱(TITLE) Micro SD 7.1 H2.25 PUSH-PUSH	
.X ± 0.30	.X ° ± 2°		
.XX ± 0.20	.XX ° ± 1°		
單 位(UNIT) mm	料 號(PART NO.) 7MSD7-F0-0002	圖 號(DWG NO.) 7MSD7-F0-0002	圖 號(DWG NO.) 7MSD7-F0-0002
審 核(APPROVAL)	核 對(CHECKED)	製 圖(DRAWN)	比 例 SCALE 1:1
			張 數 SHEET 1
			更 改 REV A

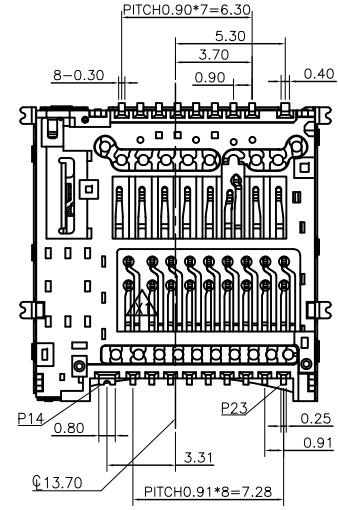
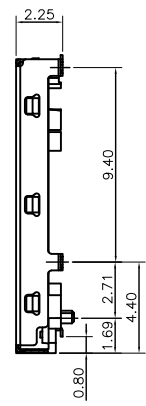
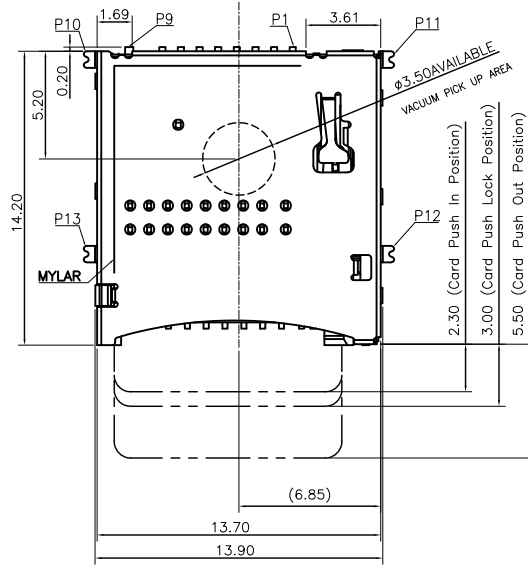
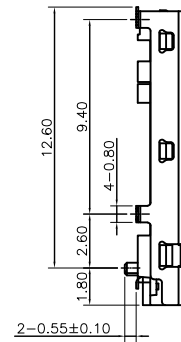
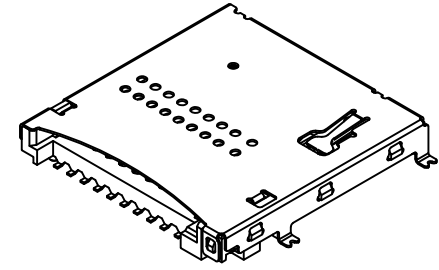
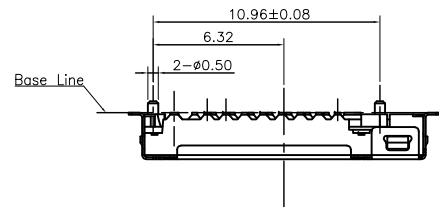

更改 REV	改 修 内 容
A	ECXXXXA

- Note :
- Material :
    - 1-1. Plastic: LCP 232, Black, UL94V-0
    - 1-2. Contact: C7025H
    - 1-3. Shell: SUS304
  - Plating :
    - 2-1. Contact :  
Contact Area: Au 15u" min. Plating Over Ni 50u" min.  
Soldertail: Matted TIN 100u" min. Over Ni 50u" min.
    - 2-2. Shell :  
Solderability Ni 50μ" min. Over All
  - Contact And Tail Coplanarity To Be 0.10mm max.

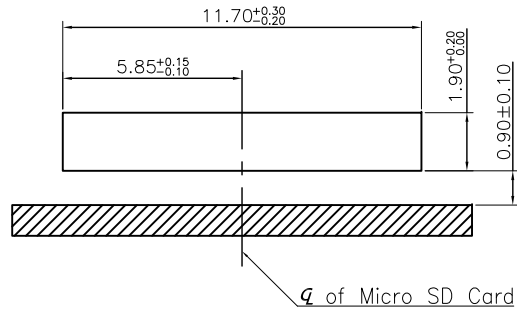

Recommended ID Dimension

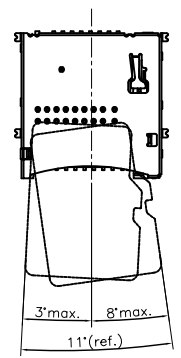

△ Card Insertion Guide Angle

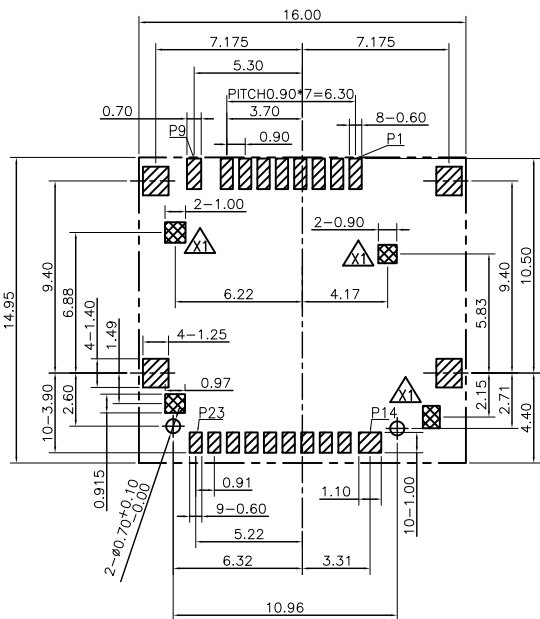

Recommended PCB Layout  
Top View (Tolerance ± 0.05)

- Pad Area
- OTHER COMPONENT KEEPOUT AREA
- RED GLUING AREA

Pin No.	Pin Assignment (UHS-II microSD Card)	Description	Pin Assignment (microSD Express Card)
P1	Micro SD DAT2	Data Line [Bit 2]	Micro SD DAT2
P2	Micro SD CD/DAT3	Card Detect/Data Line [Bit 3]	Micro SD CD/DAT3
P3	Micro SD CMD	Command/Response	Micro SD CMD
P4	Micro SD VDD1	Supply voltage (3.3V)	Micro SD VDD1
P5	Micro SD CLK	Clock	Micro SD CLK
P6	Micro SD VSS	Supply voltage ground	Micro SD VSS
P7	Micro SD DAT0/RCLK+	Data Line [Bit 0]/ RCLK+	Micro SD DAT0/RCLK+
P8	Micro SD DAT1/RCLK-	Data Line [Bit 1]/ RCLK-	Micro SD DAT1/RCLK-
P9	Micro SD VDD2	Supply voltage (1.8V)	Micro SD VDD2
P10	Micro SD VSS	Supply voltage ground	Micro SD VSS
P11	Micro SD D0+	UHS-II D0+	PCIe Tx +
P12	Micro SD D0-	UHS-II D0-	PCIe Tx -
P13	Micro SD VSS	Supply voltage ground	Micro SD VSS
P14	Micro SD D1-	UHS-II D1-	PCIe Rx -
P15	Micro SD D1+	UHS-II D1+	PCIe Rx +
P16	Micro SD VSS	Supply voltage ground	VSS
P17	Micro SD SWIO	Single Wire Protocol Interface	VDD3
P18	Micro SD CD		Micro SD CD
P19	GND		GND
P20	GND		GND
P21	GND		GND
P22	GND		GND
P23	GND		GND

	Card Detect Switch
Card Uninsertion	Open
Card Half Insertion	Open
Card Insertion	Close

Open

Close

GENERAL TOLERANCE		KINGCONN 皇海科技股份有限公司
X ± 0.50	X° ± 5°	
.X ± 0.30	.X° ± 2°	
.XX ± 0.20	.XX° ± 1°	名 称(TITLE) Micro SD 7.1 H2.25 PUSH-PUSH
单 位(UNIT) mm	料 号(PART NO.) 7MSD7-F0-0002	图 号(DWG NO.) 7MSD7-F0-0002
审 核(APPROVAL)	核 对(CHECKED)	制 图(DRAWN)
SCALE 1:1		张 数(SHEET) 2/2
PROJ.		更改 REV A

