

更改 REV	變更內容 MODIFICATION
A	ECXXXXX

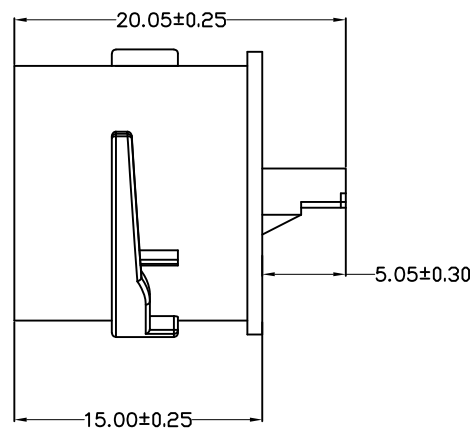
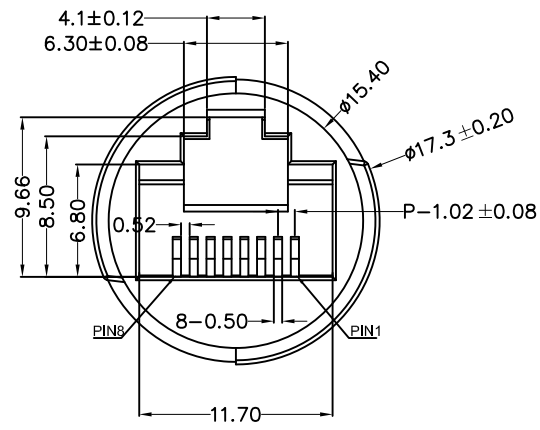

MATERIAL:
 HOUSING: PBT+25%GF+LCP, HB ,BLACK.
 TERMINAL: PHOSPHOR BRONZE T=0.35MM,
 1U" GOLD PLATING ON CONTACT AREA.

MACHANICAL:
 DURABILITY: 750 CYCLES MIN,12.5MM/MINUTE.
 INSERTION FORCE: 2.2KG.F MAX.
 RETENTION STRENGTH : 7.7KG.F BETWEEN JACK AND PLUG.
 OPERATING TEMPERATURE: -40°C~+85°C.
 STORAGE TEMPERATURE: -40°C~+85°C.

ELECTRICAL:
 VOLTAGE: 125 VOLTS AC.
 CURRENT RATING : 1.5AMP.
 DIELECTRIC STRENGTH: 1000 VAC RMS 50HZ OR 60HZ,1MIN.
 INSULATION RESISTANCE: 500 MEGA OHMS MIN. INITIAL
 AFTER 500V DC FOR 1 MINUTE.
 CONTACT RESISTANCE: SINGLE TERMINAL 30 MILLIOHMS MAX.
 INITIAL 50 MILLIOHMS MAX. AFTER
 DURABILITY TEST.

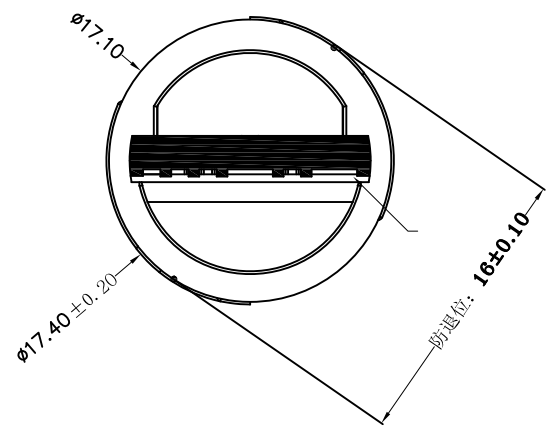
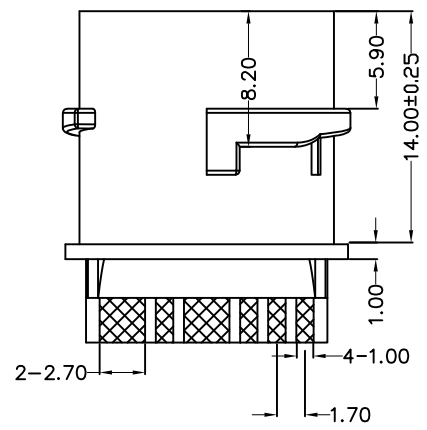

GENERAL TOLERANCE		KINGCONN 皇海科技股份有限公司
X± 0.50	X*± 5 °	
.X± 0.30	.X*± 2 °	
.XX± 0.20	.XX*± 1 °	名稱(TITLED) RJ45 圓形防水IP67 母座
單位(UNIT) mm	料號(PART NO.) 7RJ45-F0-7001	圖號(DWG NO.) 7RJ45-F0-7001
審核(APPROVAL)	核對(CHECKED)	製圖(DRAWN)
		比例 SCALE 1:1
		張數 SHEET 1/1
		更改 REV A

