

更改 REV	变更内容 MODIFICATION
A	EC04221

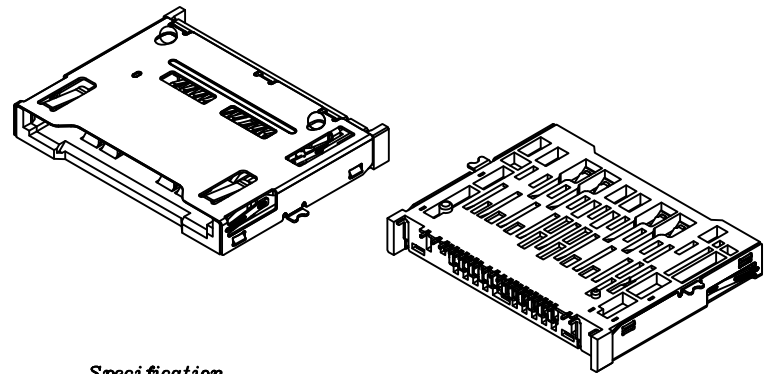
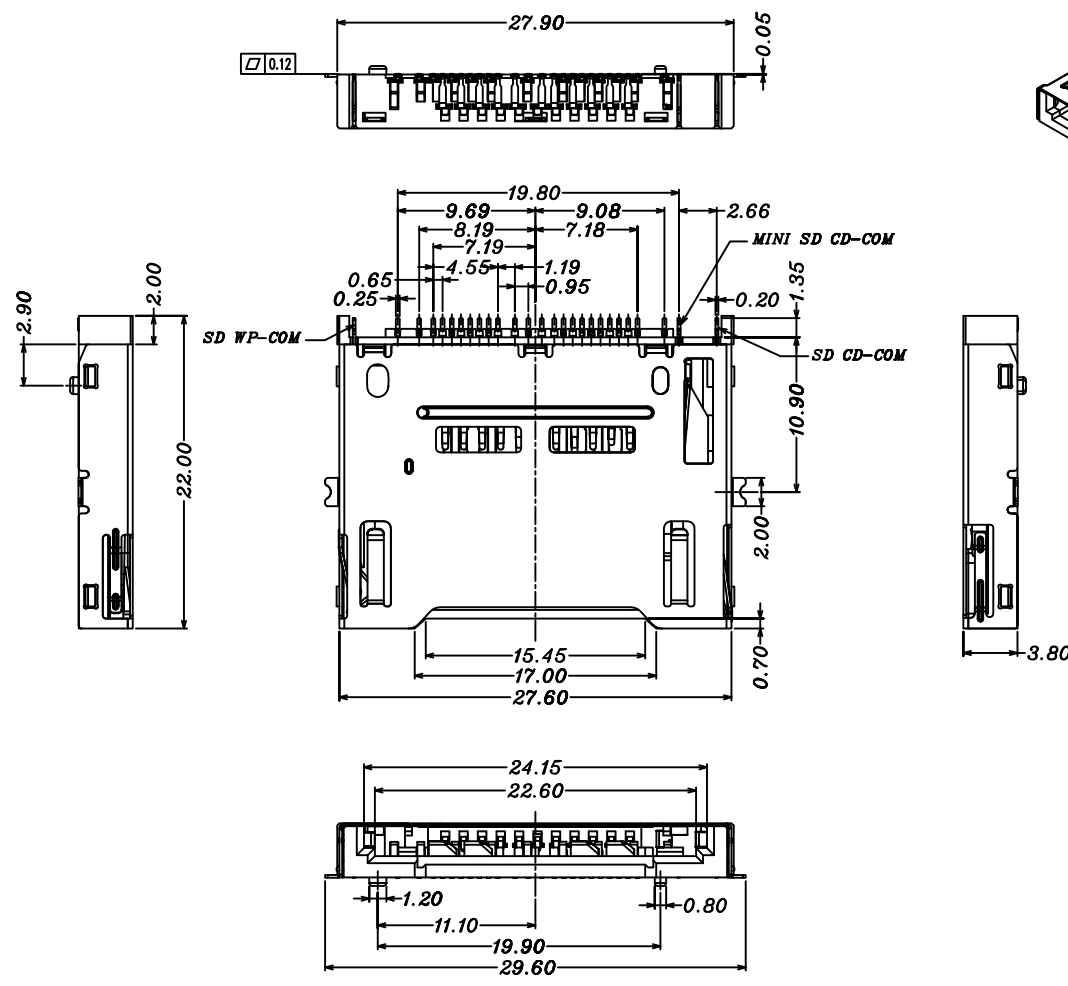

Specification

***Electrical Characteristics:**
Current Rating: 0.5A.
Withstanding Voltage: AC500V r.m.s.
Insulation Resistance: 1000 MΩ Minimum at DC 500V
Contact Resistance: 40 mΩ Maximum.

***Mechanical Characteristics:**
Mating Cycles: Total 10,000 Insertions.

***Environmental:**
Operating Temperature: -20°C~+85°C
Storage Temperature: -40°C~+70°C

***Material:**
Insulation: HI-Temp plastic UL 94V-0 Rated.
Contact: Copper Alloy.
PAD: Copper Alloy

SD CARD Total Mating Force : 40N (MAX) at 25 mm/minute;
Total Unmating Force: 1.5N (MIN) at 25 mm/minute

MINISD CARD Total Mating Force : 40N (MAX) at 25 mm/minute;
Total Unmating Force : 1.0N (MIN) at 25 mm/minute;



GENERAL TOLERANCE		KINGCONN 皇海科技股份有限公司
X± 0.50	X*± 5°	
X± 0.30	X*± 2°	
.XX± 0.20	.XX*± 1°	名 稱(TITLE) SD 6IN1 板上
單 位(UNIT) mm	料 號(PART NO.) 7SDMM-FA-0020	圖 號(DWG NO.) 7SDMM-FA-0020-A
審 核(APPROVAL)	核 對(CHECKED)	製 圖(DRAWN)
SCALE 1:1		張 數 SHEET 1 / 3
PROJ.		更 改 REV A

更改 REV	註 變 內 容 MODIFICATION
A	EC04221

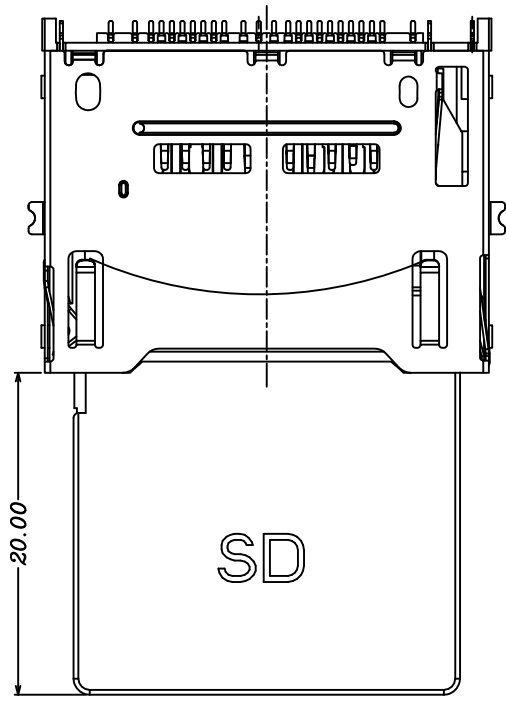

SD CARD/MMC/MMC4.0

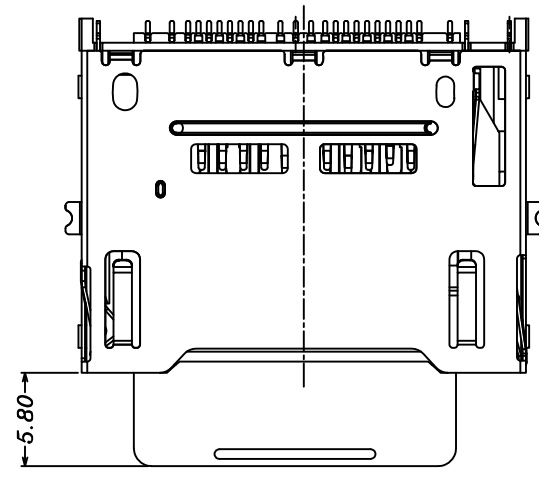

MINISD CARD

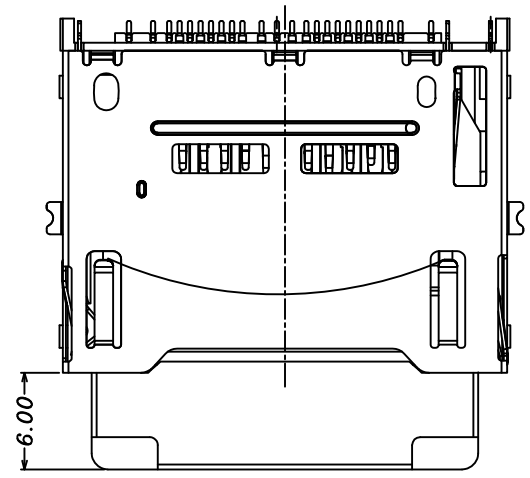

RS-MMC/RS-MMC4.0

GENERAL TOLERANCE		KINGCONN 皇海科技股份有限公司	
X± 0.50	X*± 5°	名 稱(TITLE) SD 6IN1 板上	
X± 0.30	X*± 2°		
.XX± 0.20	.XX*± 1°		
單 位(UNIT) mm	料 號(PART NO.) 7SDMM-FA-0020	圖 號(DWG NO.) 7SDMM-FA-0020	
審 核(APPROVAL)	核 對(CHECKED)	製 圖(DRAWN)	比 例 SCALE 1:1
			張 數 SHEET 3 / 3
			更 改 REV A



Pin No.	MINI SD	SD	RS-MMC/MMC	RS-MMC4.0/MMC4.0
P1	RS-MMC4.0-DAT1 SD-DAT1	8P		8P
P2	RS-MMC-RSV/RS-MMC4.0-DAT0 SD-DAT0	7P	7P	7P
P3	RS-MMC4.0-DAT7			13P
P4	MINI-SD-DAT1	8P		
P5	RS-MMC-Vss2/RS-MMC4.0-Vss2 SD-Vss2	6P	6P	6P
P6	MINI-SD-DAT0	7P		
P7	RS-MMC4.0-DAT6			12P
P8	MINI-SD-VSS2	6P		
P9	RS-MMC-CLK/RS-MMC4.0-CLK SD-CLK	5P	5P	5P
P10	MINI-SD-CLK	5P		
P11	MINI-SD-VDD	4P		
P12	RS-MMC-VDD/RS-MMC4.0-VDD SD-VDD	4P	4P	4P
P13	MINI-SD-NC	11P		
P14	MINI-SD-NC	10P		
P15	RS-MMC-Vss1/RS-MMC4.0-Vss1 SD-Vss1	3P	3P	3P
P16	MINI-SD-Vss1	3P		
P17	RS-MMC4.0-DAT5			11P
P18	MINI-SD-CMD	2P		
P19	RS-MMC-CMD/RS-MMC4.0-CMD SD-CMD	2P	2P	2P
P20	MINI-SD-CD/DAT3	1P		
P21	RS-MMC4.0-DAT4			10P
P22	MINI-SD-DAT2	9P		
P23	RS-MMC-DAT3/RS-MMC4.0-DAT3 SD-CD/DAT3	1P	1P	1P
P24	SD-DAT2	9P		9P

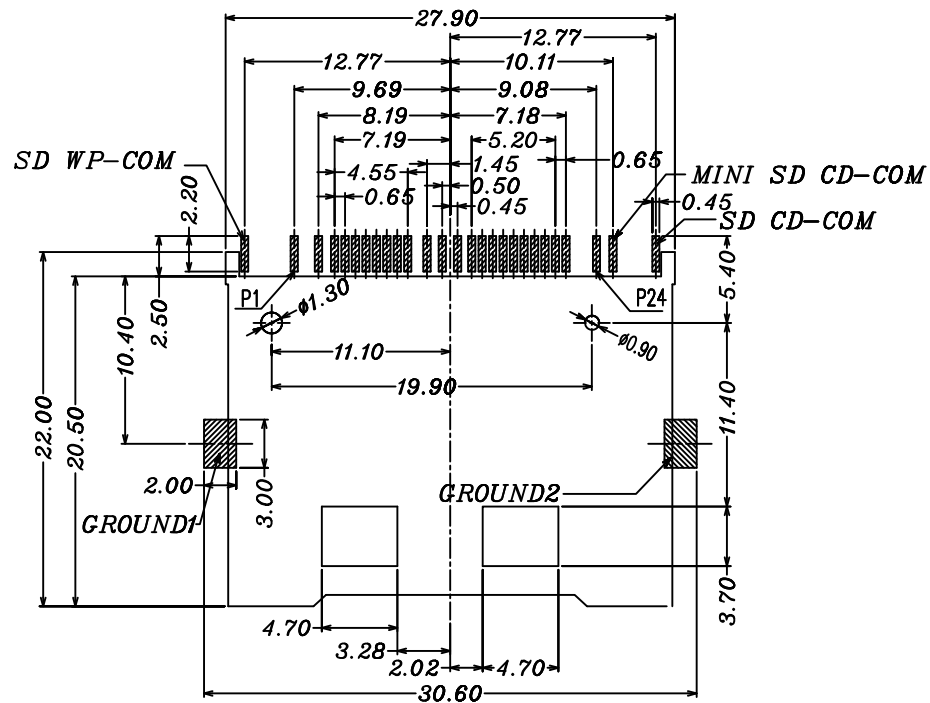

RECOMMENDED P.C.B LAYOUT
(General tolerance ± 0.05)

GENERAL TOLERANCE		KINGCONN 皇海科技股份有限公司	
X \pm 0.50	X* \pm 5°	名 稱(TITLE) SD 6IN1 板上	
X \pm 0.30	X* \pm 2°		
.XX \pm 0.20	.XX* \pm 1°		
單位(UNIT) mm	料 號(PART NO.) 7SDMM-FA-0020	圖 號(DWG NO.) 7SDMM-FA-0020	
審 核(APPROVAL)	核 數(CHECKED)	製 圖(DRAWN)	比 例 SCALE 1:1
			張 數 SHEET 2 / 3
			更 改 REV A

