

更改 REV	数量 MODIFICATION
A	ECXXXX

NOTES:
 MATERIALS:
 HOUSING : ENGINEERING THERMOPLASTIC
 UL 94V-0. BLACK
 CONTACT : COPPER ALLOY
 COVER : COPPER ALLOY
 FINISH:
 CONTACT AREA: GOLD OVER NICKEL.
 SOLDER AREA : TIN OVER NICKEL.
 PERFORMANCE CHARACTERISTICS:
 CURRENT RATING : 0.5 A AC DC
 VOLTAGE RATING : 500VAC MIN.
 CONTACT RESISTANCE : 100 MILLIOHMS MAX.
 INSULATION RESISTANCE : 1000 MEGOHMS MIN . AT 500VDC.
 OPERATING TEMPERATUER : -25°C TO 85°C.

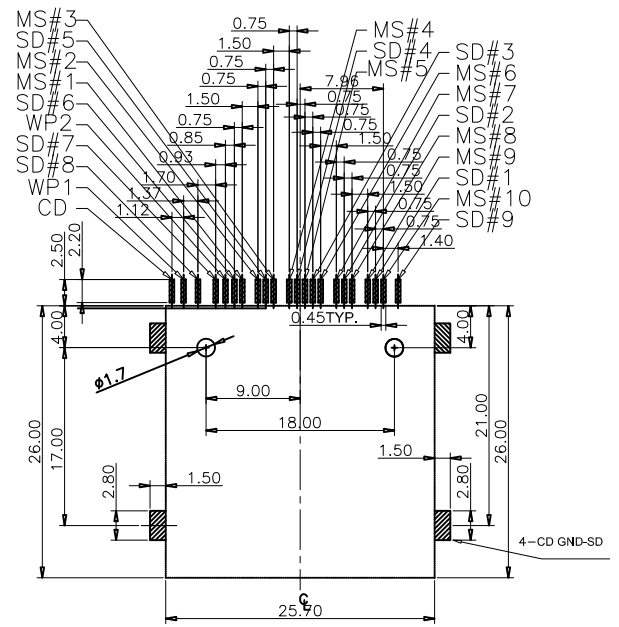
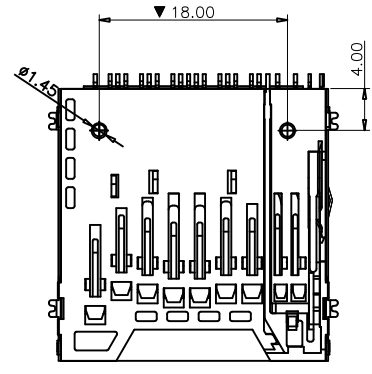
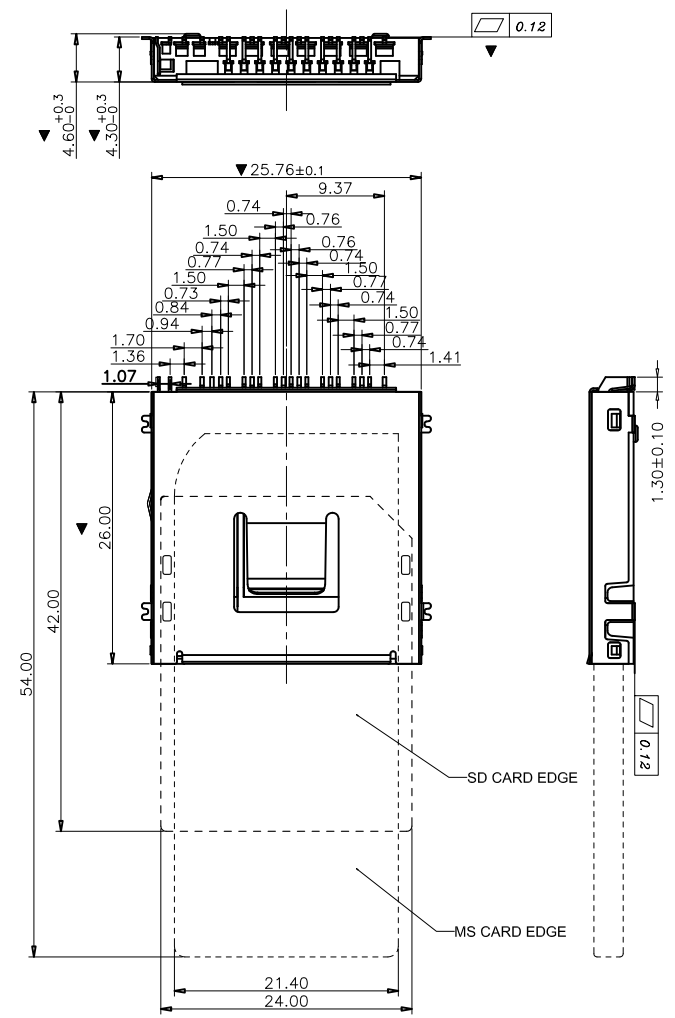

PCB LAYOUT

MS CARD PIN DESIGN		
Pin#	Name	Description
1#	VSS	
2#	BS	
3#	VCC	
4#	DIO	
5#	RESERVE	
6#	INS	
7#	RESERVE	
8#	SCLK	
9#	VCC	
10#	VSS	

SD CARD PIN DESIGN		
Pin#	Name	Description
1#	CD/DAT3	Card Detect/DATA 1/0
2#	CMD	COMMAND
3#	Vss1	GROUND
4#	Vcc	POWER
5#	CLK	Clock
6#	Vss2	GROUND
7#	DAT0	Data 1/0
8#	DAT1	Data 1/0
9#	DAT2	Data 1/0

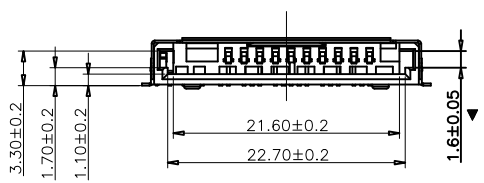

GENERAL TOLERANCE		KINGCONN 皇海科技股份有限公司	
X± 0.50	X°± 5°	名廠(TITLE)	
X± 0.30	X°± 2°	SD MS MMC 3IN1 CARD A TYPE	
.XX± 0.20	.XX°± 1°	圖號(DWG NO.)	
單位(UNIT)	料號(PART NO.)	圖號(DWG NO.)	
mm	7SDMS-F0-0002	7SDMS-F0-0002	
審核(APPROVAL)	核對(CHECKED)	製圖(DRAWN)	比例(SCALE)
			1:1
			張數(SHEET)
			1/1
			更改(REV)
			A

