

更改 REV	数量 MODIFICATION
A	ECXXXXX

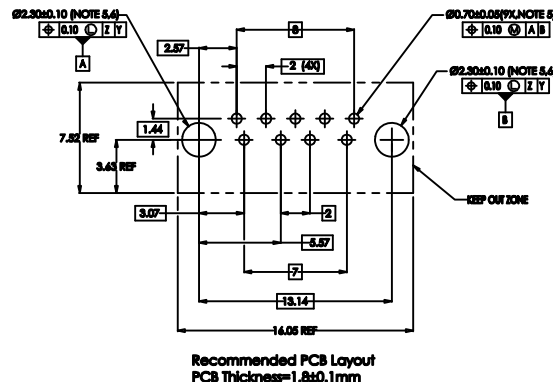
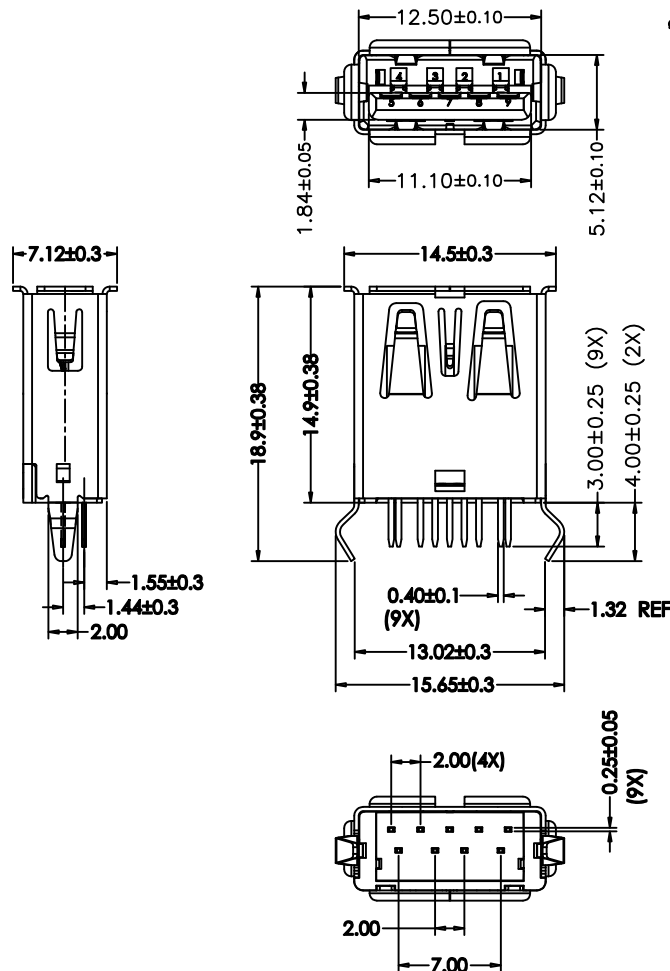

NOTE:

1. MATERIAL:

1.1 INSULATOR:HIGH TEMPERATURE PLASTIC

1.2 CONTACT:BRONZE

1.3 SHELL:BRASS

2. ELECTRICAL CHARACTERISTICS;

2.1 CONTACT RESISTANCE:30mΩ MAX

2.2 CONTACT CURRENT RATING:1.5A

2.3 DIELECTRIC WITHSTANDING VOLTAGE:100 V R. M. S.

2.4 INSULATION RESISTANCE 100 MΩ MIN

2.5 OPERATING TEMPERATURE:-40° C ~ 85° C

3 MECHANICAL CHARACTERISTICS:

3.1 MATING FORCE:3.57kgf MAX

3.2 UNMATING FORCE:1.02kgf MIN

3.3 DURABILITY:MANDATORY:1,500 CYCLES

4. PLATING

4.1 TERMINAL:

50u" MIN NICKEL ALL OVER

120u"MIN Tin ON SOLDER AREA

(1~30)u"Au ON CONTACT AREA

4.2 SHELL:50u"MIN. NICKEL ALL OVER

Pin NUMBER	SIGNAL NAME
1	VBUS
2	D-
3	D+
4	GND
5	StdA_SSRX-
6	StdA_SSRX+
7	GND_DRAIN
8	StdA_SSTX-
9	StdA_SSTX+
Shell	Shield

GENERAL TOLERANCE		KINGCONN 皇海科技股份有限公司
X± 0.50	X*± 5°	
.X± 0.30	.X*± 2°	
.XX± 0.20	.XX*± 1°	名称(TITLE) USB3.0 AF 180度 DIP 弯脚 有卷边 L:14.9mm
单位(UNIT) mm	料号(PART NO.) 7USB3-F0-0016	图号(DWG NO.) 7USB3-F0-0016
审核(APPROVAL)	核数(CHECKED)	制图(DRAWN)
比例(SCALE) 1:1	张数(SHEET) 1/1	更改(REV) A

